

Reference

This is a reference document. Specifications and dimensions are subject to change without notice.

Miniature Work Support **PAT.**

The World's Smallest Thread Size **M16** × 1.0



Model **LD0162**
Hydraulic Model
(Standard)



Model **LD0162-S**
Hydraulic Model
(Short Body)



Model **WNC0100**
Pneumatic Model
(Standard)

Work Support prevents chattering and deformation caused by thrust load during workpiece machining.

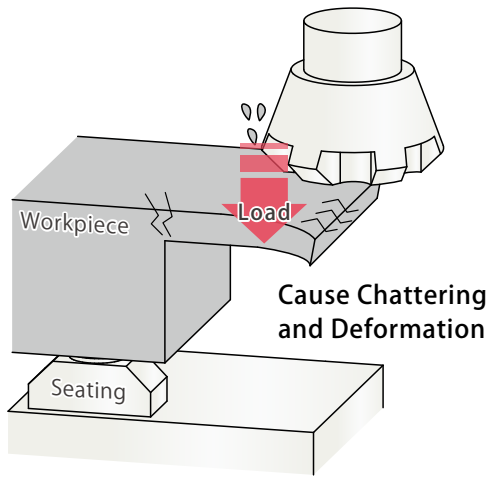

< Without Work Support >

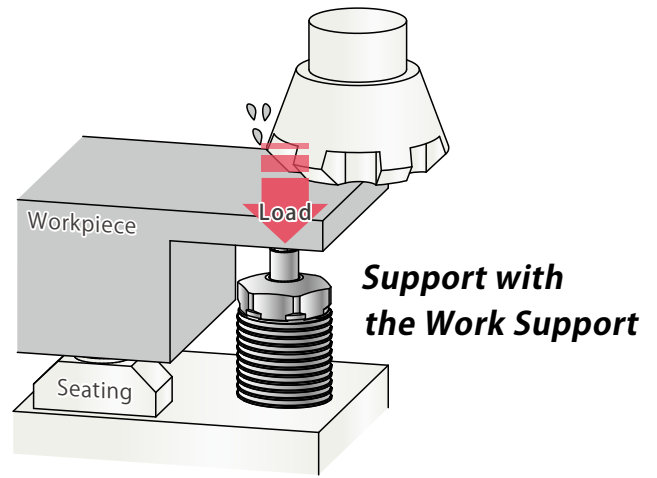

< With Work Support >

Excellent machining quality with multiple work supports

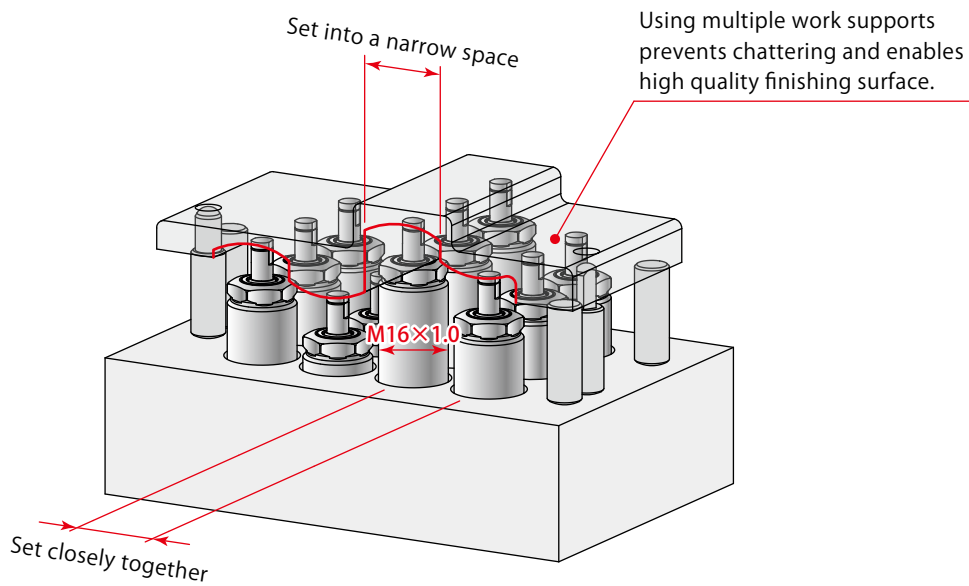

● Application Examples

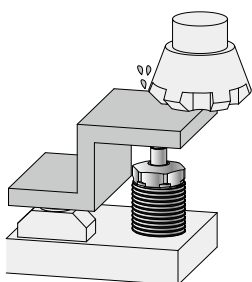

To avoid chattering of a thin workpiece

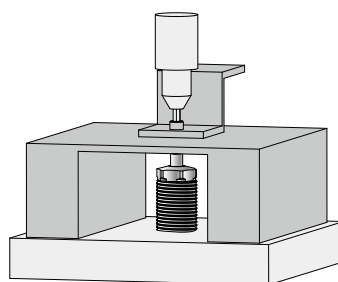

To back up a screw fastening machine, etc.

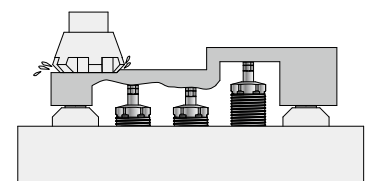

To support an uneven workpiece

● Model No. : Hydraulic Advance Model

LD 016 2 - L - S

1
 2
 3
 4

1 Body Size

016 : External Thread M16×1.0

2 Design No.

2 : Revision Number

3 Plunger Spring Force

L : Low Spring Force
H : High Spring Force

4 Options

Blank : Hydraulic Advance Model (Standard)
S : Hydraulic Advance Short Model

● Model No. : Pneumatic Advance Model

WNC 010 0 - L

1
 2
 3

1 Support Force

010 : Support Force 0.12kN at 0.5MPa

2 Design No.

0 : Revision Number

3 Plunger Spring Force

L : Low Spring Force
H : High Spring Force

● Specifications : Hydraulic Advance Model

Model No.		LD0162-□	LD0162-□-S
Support Force (at 7MPa)	kN	1.0	0.32
Plunger Stroke	mm	5.0	4.0
Effective Stroke	mm	4.7	3.7
Cylinder Capacity	cm ³	0.15	0.07
Plunger Spring Force	L : Low Spring N	1.2 ~ 1.7	1.0 ~ 1.6
	H : High Spring N	1.5 ~ 2.4	1.2 ~ 2.4
Max. Operating Pressure	MPa	7.0	
Min. Operating Pressure	MPa	2.5	
Withstanding Pressure	MPa	10.5	
Usable Fluid		General Hydraulic Oil Equivalent to ISO-VG-32	
Operating Temperature	°C	0 ~ 70	
Weight	g	40	30

● Specifications : Pneumatic Advance Model

Model No.		WNC0100-□
Support Force	at 0.7MPa kN	0.22
	at 0.5MPa kN	0.12
Plunger Stroke	mm	5.0
Effective Stroke	mm	4.7
Cylinder Capacity	cm ³	0.34
Plunger Spring Force	L : Low Spring N	1.2 ~ 1.7
	H : High Spring N	1.5 ~ 2.4
Max. Operating Pressure	MPa	0.7
Min. Operating Pressure	MPa	0.3
Withstanding Pressure	MPa	1.0
Usable Fluid		Dry Air
Operating Temperature	°C	0 ~ 70
Weight	g	40

● Dimensions : Hydraulic Advance Model

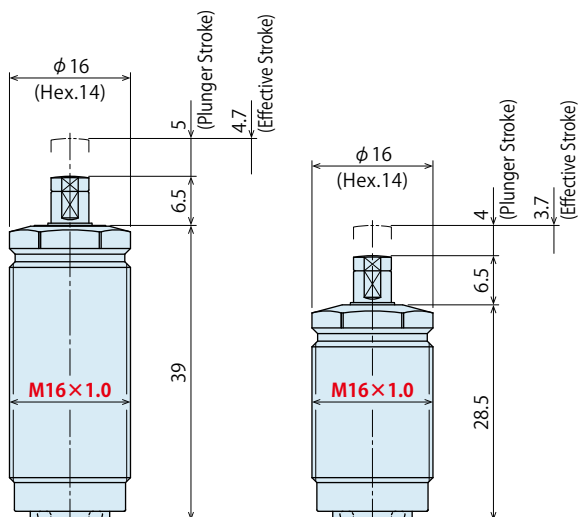

● Dimensions : Pneumatic Advance Model

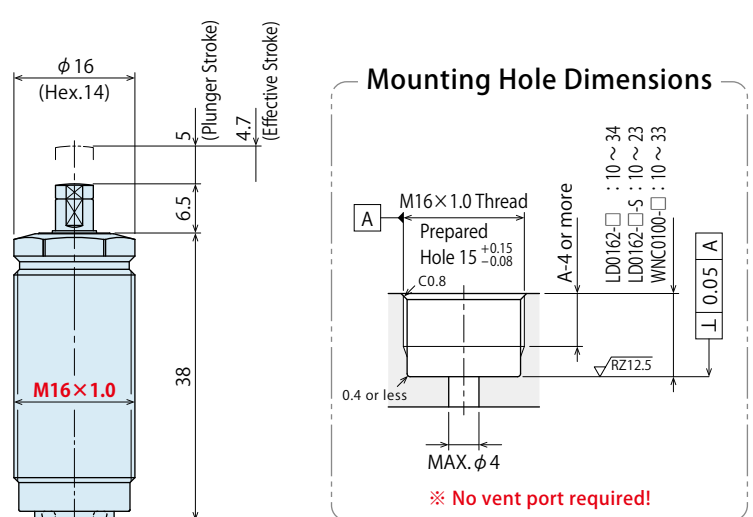

The World's Smallest Work Supports!

※ Showing the standard models only. Please contact us or visit our website (<http://www.kosmek.co.jp/english/>) for more options!

● High-Power Pneumatic Model

model **WNC** Threaded Body

7 Body Sizes Available

- Support Force (at Air Pressure 0.5MPa)
0.12kN ~ 5.7kN
- External Thread Size
M16×1.0 ~ M60×1.5



● Pneumatic Rodless Hollow Model

model **WNA** Flanged Body

6 Body Sizes Available

- Support Force (at Air Pressure 0.5MPa)
0.25kN ~ 4.0kN



● Hydraulic Single Acting Model

model **LD** Threaded Body

6 Body Sizes Available

- Support Force (at Hyd. Pressure 7.0MPa)
1.0kN ~ 10.0kN
- External Thread Size
M16×1.0 ~ M45×1.5



● Hydraulic Single Acting Model

model **LC** Flanged Body

9 Body Sizes Available

- Support Force (at Hyd. Pressure 7.0MPa)
2kN ~ 65kN



● Hydraulic Single Acting Model

model **TNC** Threaded Body

4 Body Sizes Available

- Support Force (at Hyd. Pressure 35MPa)
4.4kN ~ 16.3kN
- External Thread Size
M26×1.5 ~ M45×1.5



● Hydraulic Double Acting Model

model **TND** Threaded Body

3 Body Sizes Available

- Support Force (at Hyd. Pressure 35MPa)
7.1kN ~ 16.3kN
- External Thread Size
M32×1.5 ~ M48×1.5



● Hydraulic Single Acting Model

model **TC** Flanged Body

5 Body Sizes Available

- Support Force (at Hyd. Pressure 25MPa)
10kN ~ 65kN





KOSMEK Work Clamping Systems Complete Catalog

Find further information on our catalog.
You can order the catalog from our website
(<http://www.kosmek.co.jp/english/>).



KOSMEK LTD.

▶ <http://www.kosmek.com/>

HEAD OFFICE 1-5, 2-chome, Murotani, Nishi-ku, Kobe-city, Hyogo, Japan 651-2241
TEL.+81-78-991-5162 FAX.+81-78-991-8787

United States of America SUBSIDIARY	KOSMEK (USA) LTD. 650 Springer Drive, Lombard, IL 60148 USA TEL. +1-630-620-7650 FAX. +1-630-620-9015
MEXICO REPRESENTATIVE OFFICE	KOSMEK USA Mexico Office Av. Santa Fe #103 int 59 Col. Santa Fe Juriquilla C.P. 76230 Queretaro, Qro Mexico TEL. +52-442-161-2347
EUROPE SUBSIDIARY	KOSMEK EUROPE GmbH Schleppeplatz 2 9020 Klagenfurt am Wörthersee Austria TEL. +43-463-287587 FAX. +43-463-287587-20
CHINA SUBSIDIARY	KOSMEK (CHINA) LTD. Room601, RIVERSIDE PYRAMID No.55, Lane21, Pusan Rd, Pudong Shanghai 200125, China TEL. +86-21-54253000
INDIA BRANCH OFFICE	KOSMEK LTD. - INDIA F 203, Level-2, First Floor, Prestige Center Point, Cunningham Road, Bangalore -560052 India TEL.+91-9880561695
THAILAND REPRESENTATIVE OFFICE	KOSMEK Thailand Representation Office 67 Soi 58, RAMA 9 Rd., Suanluang, Suanluang, Bangkok 10250, Thailand TEL. +66-2-300-5132 FAX. +66-2-300-5133

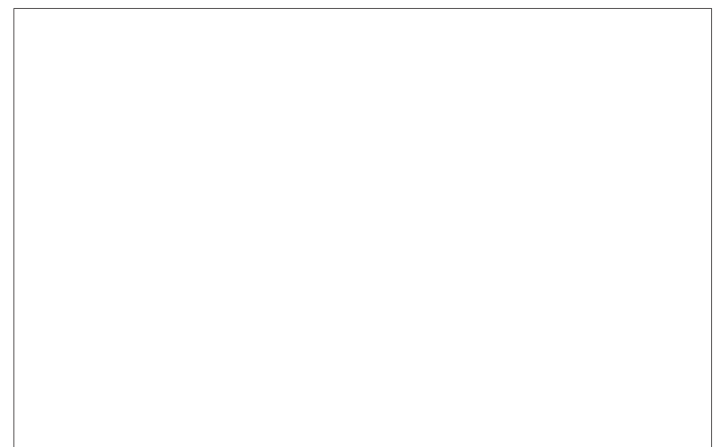

- For Further Information on Unlisted Specifications and Sizes, Please call us.
- Specifications in this Leaflet are Subject to Change without Notice.

